

3.2 Name and function of each section

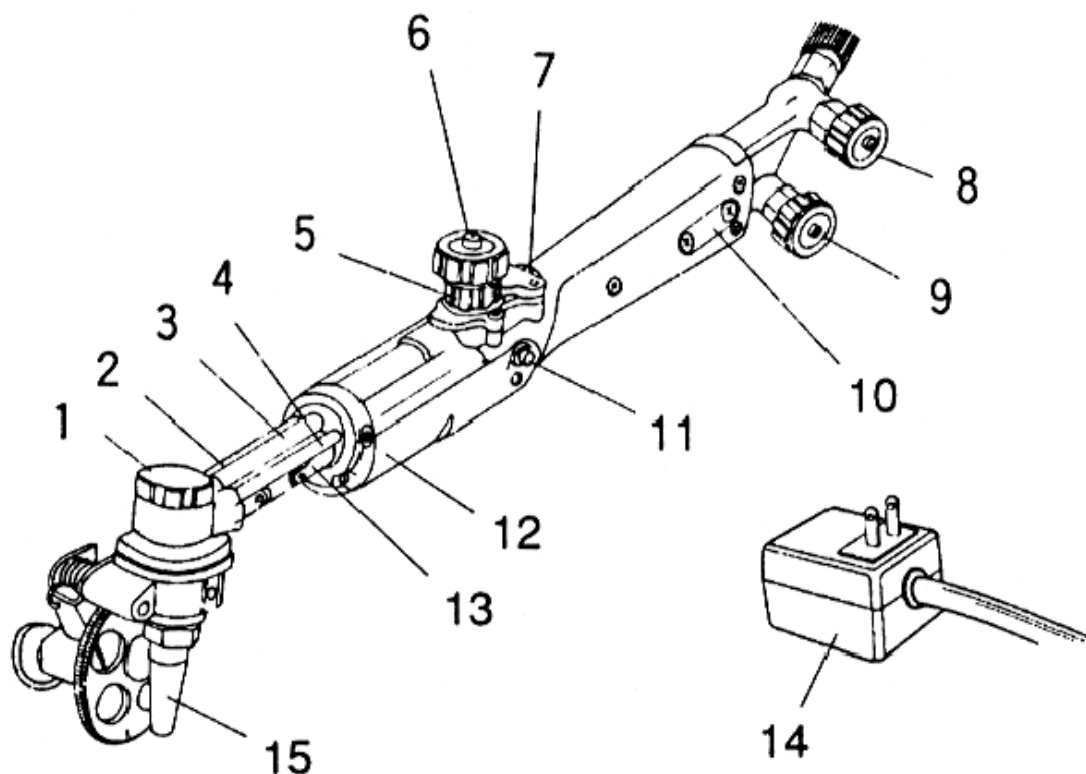

1. Wheel locking knob

The wheel can change the position by 360° when the knob is loosened.

2. Fuel gas tube

3. Cutting oxygen tube

4. Preheating oxygen tube

5. Drive switch

The drive switch is interlocked with the cutting oxygen valve.

6. Cutting oxygen valve

Turn the valve to feed cutting oxygen.

7. Speed control knob

Turn the knob in the direction of H to move the machine quickly and to L to move slowly.

8. Preheating oxygen valve

Turn the valve to feed preheating oxygen.

9. Fuel gas valve

Turn the valve to feed fuel gas.

10. Fuse

11. Normal/reverse rotation changeover button switch

The switch changes the direction of the rotation and traveling.

12. Motor

Mounted inside the HANDY AUTO.

13. Universal joint

14. AC adapter

Insert the adapter into the power supply.

※ Adapters contain electronic components inside. Dropping or hitting them can cause the internal electronic parts to break.

Please handle with care.

15. Tip

3.3 Specifications

1. Weight (main unit)	: 6 pound
Handy auto kit	: 17.2 pound
2. Machine size	: 19.7 × 2.7 × 5.8 inch (With standard wheel assembly)
3. Wheel drive	: Friction drive
4. Power source	: ± 10%
5. Speed control method	: Transistor control

6. Cutting speed : 5.9~20.9 inch/min
 7. Cutting Thickness : 0.2~1.2 inch (by standard accessories)
 8. Motor : DC 12V 7200 r.p.m. reducer 1/400

- Optional attachments : Auxiliary wheel assembly
 : Beveling wheel assembly (22° ~45°)
 : Small circle cutting attachment (ϕ 1.2 ~ ϕ 7.9inch)
 : Guide lever
 : Large circle cutting attachment (ϕ 4.7 ~ ϕ 19.7inch)
 : Straight rail (19.7inch)

4 Preparation for operation

4.1 Contents of package

Carefully take the machine out of the case.

First, please check your unit to make sure it is complete.

The following is a list of the standard parts you should receive.

STANDARD PACK

- | | |
|---|--------|
| 1) Main unit | :1 set |
| 2) Standard wheel assembly | :1 set |
| 3) Spanner | :1 pc |
| 4) Fuse(mizett, 1A) | :2 pcs |
| 5) Tip (102 or 106 type #0,1,2, one each) | :3 pcs |

HANDY AUTO KIT

- | | |
|---|--------|
| 1) Main unit | :1 set |
| 2) Standard wheel assembly | :1 set |
| 3) Auxiliary wheel assembly | :1 set |
| 4) Beveling wheel assembly | :1 set |
| 5) Small circle cutting attachment | :1 set |
| 6) Guide lever | :1 pc |
| 7) Spanner | :1 pc |
| 8) Fuse(mizett, 1A) | :2 pcs |
| 9) Tip (102 or 106 type #0,1,2, one each) | :3 pcs |
| 10) Steel carrying case | :1 pc |
| 11) Tip cleaner | :1 pc |

4.2 Machine assembly

- Carefully take the machine out of its case.
- Attach the primary hose to the gas distributor.

- (1)Oxygen hose (green) to the top position hose nipple
 (2)Gas hose (red) to the bottom position hose nipple

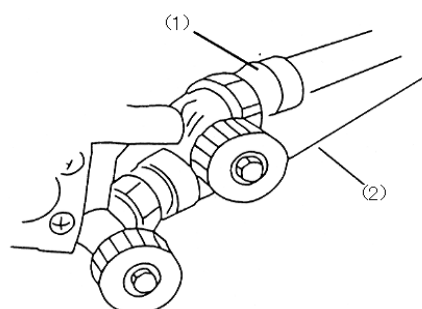

4.3 Preparation for operation

4.3.1 Connecting the power cable

1. Connect the metallic plug on the AC adapter side with the metallic receptacle on the machine side. Before connection, check that there is no foreign substances or dust.
2. The metal plugs are screw-threaded, therefore, fully tighten them so that they will not come loose during operation.

4.3.2 Connecting the tip

1. Select a proper tip according to the thickness of the steel plate and attach it to the torch. (To select a tip, refer to the table of Cutting Data.)
- When fixing a tip to the torch, tighten the nut with the two wrenches attached.
 - If the tip is tightened excessively, it will be heated during cutting and tightened still more, making it difficult to remove the tip.
 - In addition, avoid damaging the taper of the tip since this may cause backfire.

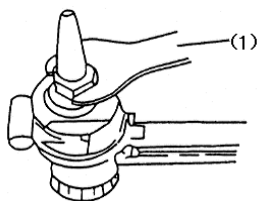

(1) Spanner

4.3.3 Installing the wheel

Insert the wheel bracket shaft into the gear cover. Pull up spring lever and hang it on the stopper.

- (1) Gear cover
- (2) Bracket shaft
- (3) Stopper
- (4) Spring

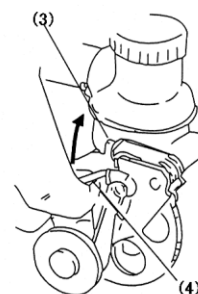
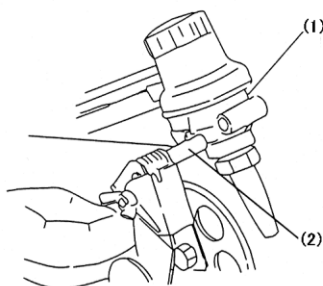

4.3.4 Fitting the wheel

As the wheel rotates a fully 360° from the center of the tip, all direction cutting is possible. Decide the position of the wheel as you like according to the material to be cut or for your positional comfort during the cutting operation.

To set the position of the wheel, loosen the wheel setting knob a little, set the position and tighten the knob up well.

- (1) Position setting knob
- (2) Direction for tightening
- (3) Direction for loosening

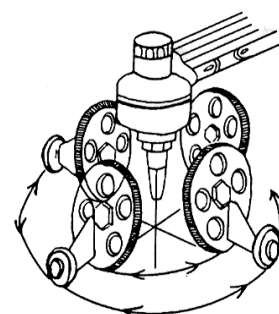
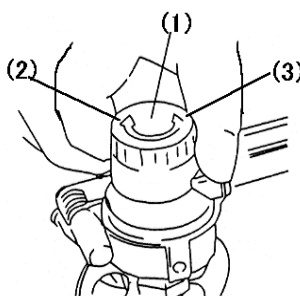

4.3.5 Cutting processes

Open the cutting oxygen valve more than 1/8 turn. This starts the motor, as the drive switch and the cutting oxygen valve are linked together. Both the drive switch and the cutting oxygen valve, however, can operate independently.

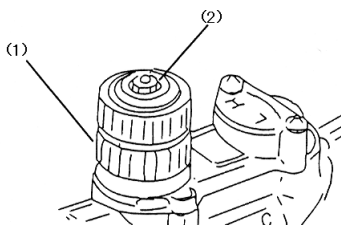
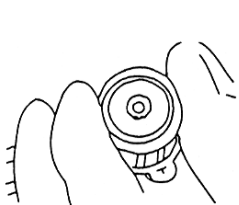

- (1) Drive switch
- (2) Cutting oxygen valve

4.3.6 Speed setting

Adjust the cutting speed with the speed adjustment knob according to the thickness of material immediately after the wheel has started rotating. Turn the knob toward the H to increase the cutting speed, and to L to decrease.

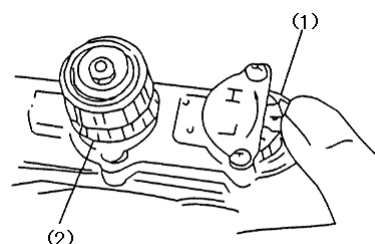

- (1) Speed adjustment knob
- (2) Drive switch

4.3.7 Changing over direction of motor rotation

To switch the direction of motor rotation, push and hold the button on the left side of the main unit until you hear a clink. Stop the motor beforehand, or the service life of the motor will be shortened, the fuse may blow, etc.

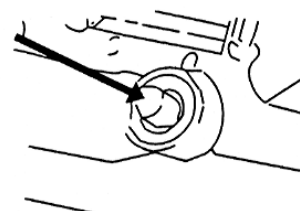

4.3.8 How to use guide roller

A guide roller is attached to the side of the wheel to stabilize the tip angle. The height of the guide roller can be adjusted by loosening the wing nut. Set it in the lower position for right-angle cutting. Select a proper height for bevel cutting in accordance with the angle to incline the machine and fix it with the wing nut.

- (1) Butterfly nut
- (2) Guide roller

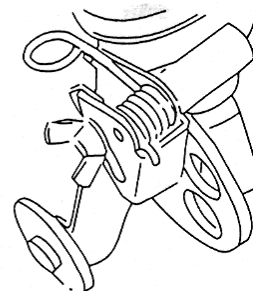
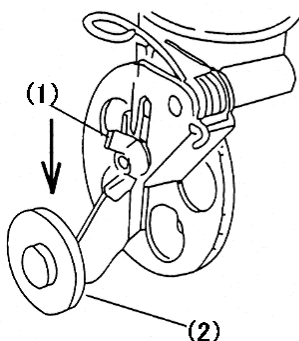

4.4 Optional attachments

4.4.1 Auxiliary wheel

This is used to add further stability to the cutting operation. To install, lift the guide roller of the square cutting attachment from the cutting material.

Then, fix the wheel with a butterfly nut.

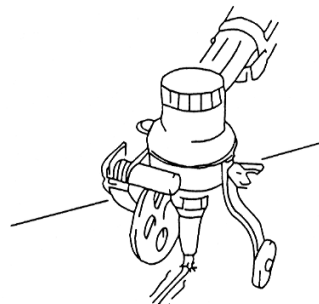

4.4.2 Beveling wheel

This is used for bevel cuts at an angle range of 22° -45°. To install, remove the square cutting attachment. Then loosen the guide roller fixing butterfly nut, adjust the position of the guide roller and set the bevel angle.

In bevel-cutting at a comparatively large angle, watch out for slip caused by dragging hoses or the condition of the material. For beveling, the use of the straight line cutting rail is recommended as this will give more stability than a hand-held operation.

For large angle beveling, use a tip one grade larger than that for straight cutting or pre-heat more thoroughly.

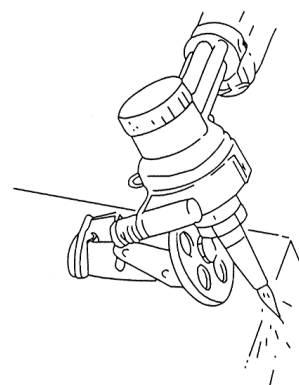

4.4.3 Small circle cutting attachment

This is used for cutting small circles of 1.2-7.9 ϕ inch

- 1) Remove the square cutting attachment.
- 2) Loosen the wheel setting knob.
- 3) Fasten the clutch knob to the gear cover firmly.
- 4) Loosening the radius setting knob, set the cutting radius and tighten the knob.
- 5) Put the drive switch to ON, and adjust the cutting speed.
- 6) The circle cutting attachment can be operated manually, by loosening the clutch knob. Decide the initial cutting position and set the attachment firmly in position.

During the circle cutting operation there may be fluctuations in the cutting speed. These are caused by hose drag, changes in the way or position the machine is held and the like being transmitted to rotation mechanism.

In cutting small circles with the small circle cutting attachment, be sure to loosen the wheel setting knob.

When cutting circles, always make sure the clutch knob is tightened.

When not cutting circles loosen or remove the clutch knob.

When you start a cut by piercing, open the cutting oxygen valve slowly after preheating to prevent cutting errors.

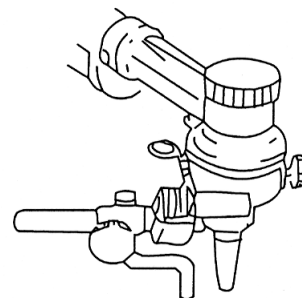

<A setup of cutting speed>

- Cutting speed differs in speed (number of rotations) by the diameter of a cutting circle, and plate thickness.
- The specification range of the small circle cutting attachment of HANDY AUTO II , They are 1.2rpm - 4.2rpm.
- Please set up from the following "related tables of cutting thickness and the diameter of cutting."

		5	5-10	10-15	15-30	Cutting thickness [mm]
		660	550~660	490~550	400~490	Cutting speed [mm/min]
Cutting diameter	30	_____	_____	_____	4.24	
	40	_____	_____	3.90	3.18	
	50	4.20	3.50	3.12	2.55	
	60	3.50	2.92	2.60	2.12	
	70	3.00	2.50	2.23	1.82	
	80	2.63	2.19	1.95	1.59	
	90	2.33	1.95	1.73	1.41	
	100	2.10	1.75	1.56	1.27	
	120	1.75	1.46	1.30	1.06	
	140	1.50	1.25	1.11	_____	
	160	1.31	1.09	_____	_____	
	180	1.17	_____	_____	_____	
200	1.05	_____	_____	_____		

This table is computing the number of rotations based on the speed of the cutting tip capability table when using a standard cutting tip. High speed divergent cutting tips should not be used, as the preheat oxygen pressure and cutting oxygen pressure can not be obtained for such use. Moreover, the above-mentioned number of rotations may change according to conditions, such as a preheat pressure values varying, the condition of the plate and the type of gas used.

Please observe the state of cutting and adjust the speed accordingly.

4.4.4 Straight line cutting rail

This is used for precise straight line cutting.
 Loosen the butterfly nut and adjust the position of the magnet along the slot in the rail bracket according to the size of the material.
 Set the rail parallel with the cutting line
 Put the guide roller in the groove on the rail.
 Be careful to maintain a horizontal grip position. Otherwise the guide roller may come off the groove, Spoiling the cut surface.

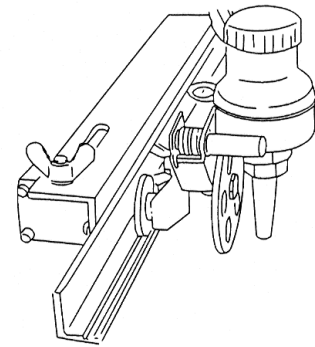

4.4.5 Manual guide lever

This is used to get further stability during the cutting operation. The use in combination with an auxiliary wheel is better.
 Remove the wheel setting knob. Insert the guide lever into position.

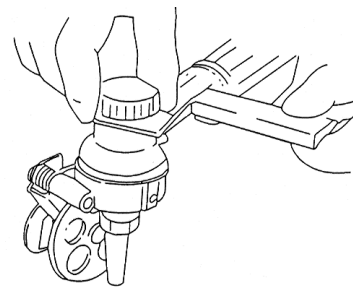

4.4.6 Large circle cutting attachment

Large circle cutting attachment(ϕ 4.7 – ϕ 19.7inch)

- (1)Wheel position fixing knob
- (2)Stopper
- (3)Adjustable holder
- (4)Radius fixing bolt
- (5)Standard wheel
- (6)Guide roller
- (7)Magnet
- (8)19.7 inch diameter Bar

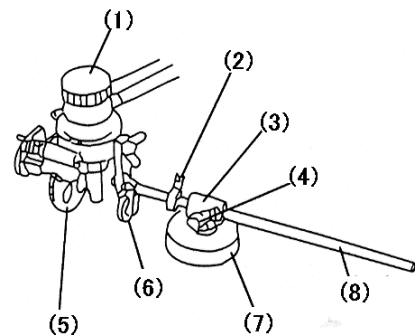

● Usage

- 1)Be sure to use the standard wheel for cutting out large circles. Raise the guide roller so that it will not touch the Steel sheet.
- 2)Fix the 19.7 inch diameter bar to the main unit with a wing bolt.
- 3)Loosen the wheel position fixing knob.

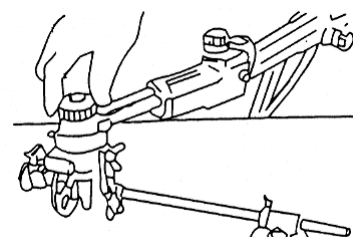
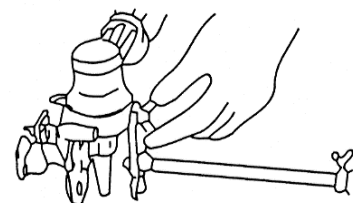

- 4) Use a magnet center to set the magnet in the center of the circle to be cut.
- 5) Set the adjustable holder in the magnet, loosen the radius fixing bolt, and adjust the cutting radius before fixing.
- ⊙ Use a stopper for in-feed cutting. When a disc is a product, set the stopper as shown in the photo, and when the hole is to be made as a product, set the stopper on the side opposite to the side shown in the photo with respect to the adjustable holder.
- 6) Turn on the drive switch, and adjust the speed.
- 7) Raise the main unit (standard wheel) from the steel sheet to move the main unit to any desired point on the circumference. Determine the cutting start position in this way.
- 8) Operation hereafter is the same as the line cutting operation. Open the Jox valve, and the standard wheel is driven automatically, to start circle cutting.

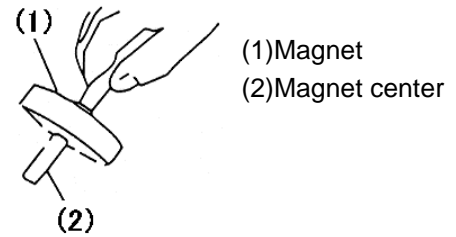

● Notice

- 1) Loosen the wheel position fixing knob to cut out circles with the large circle cutting attachment.
- 2) The drive wheel may go beyond a steel sheet when cutting its edge. Therefore, use a support roller as a manual guide for cutting.
- 3) Remove the support roller for cutting out circles of 5.9 inch diameter or less.

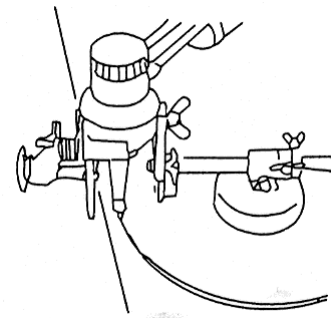

5 Cutting operation

5.1 Safety measures prior to operation

5.1.1 Precautions for handling AC adapter

1. The AC adapter cannot be repaired. When it has failed, replace it with a new one.
2. The case of the AC adapter is made from synthetic resin.
 - 1) Do not place the case in a hot place.
 - 2) Do not drop a heavy object onto the case.
 - 3) Make sure that the supply voltage is correct. The operating voltage is 100~240 VAC 10%.

5.1.2 Selection of tip

Referring to the Cutting Data, select the suitable tip according to the plate thickness.

For a heavily rusted plate or for a bevel cutting angle of more than 20°, select the tip one grade higher than the one shown in the Cutting Data.

5.1.3 Traveling direction changeover switch

1. The traveling direction changeover switch on the machine is used to change forward/backward movement for linear cutting and clockwise/counterclockwise turning for circular cutting. Check the traveling direction or turning direction before cutting.
2. To change the traveling direction, return the drive knob to the stop position. Then after the machine has stopped completely, change the traveling direction.

Note: *Before turning on the power, be sure to check that the drive knob is on the stop position. If the drive knob is on, it is dangerous to start the machine.*

5.2 Ignition and flame adjustment

Adjust the gas pressure according to the Cutting Data. The data shows the pressure when all the valves are open. Readjust the pressure after ignition.

■ Flame adjustment method

1. Open the fuel gas valves 1/4 to 1/2 a turn, and ignite the torch with an igniter.
2. Then, open the preheating oxygen valve gradually until a white cone of the standard flame has been obtained. (The incandescent area should be uniform and about 0.2-0.24 inch in length.)
3. Open the cutting oxygen valve fully. Readjust the flame if its condition has changed. A disorderly flow of the cutting oxygen will adversely affect the quality of the cutting surface. In such a case, clean the tip with a suitable cleaning needle with the cutting oxygen is flowing. (Please close gas and preheat oxygen valve before cleaning the cutting oxygen channel.)

Natural flame ensures a good quality cut surface. (Oxidized flames may be used for bevel cutting.)

The oxidized flame shortens the cutting oxygen flow, causing slug deposition or melting the upper edge of the cut surface. Excessively high cutting oxygen pressure will cause the same effect.

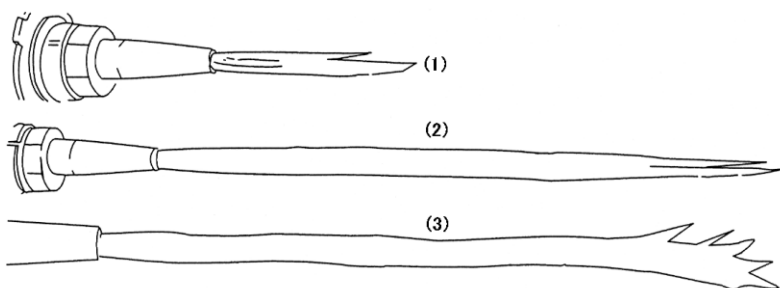

(1)Oxidizing Flame

(2)Neutral Flame

(3)Carbonizing Flame

●Preheating

For preheating, hold the grip with your right hand to support the HANDY AUTO and hold the cutting oxygen valve with the thumb and forefinger of the left hand to stabilize the HANDY AUTO.

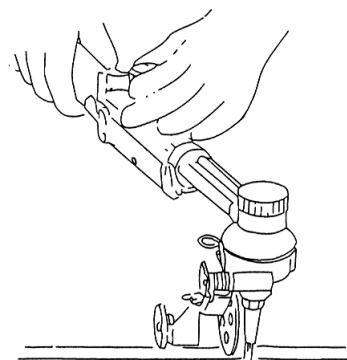

5.3 Cutting and piercing method

1. Cut in from the end of steel plate.
2. Pierce steel plate before cutting.
3. Drill a hole before cutting.

■Piercing method

- 1) Ignite and adjust the flame.
- 2) Thoroughly preheat the cut-in point until it is white hot.
- 3) Open the cutting oxygen valve to pierce the steel plate. The tip should be about 0.6-0.79 inch from the plate to prevent slag from splashing onto the tip and adhering there, which will shorten the working life of the tip.
- 4) Piercing starting from the middle of the material is not recommended, since the result heat exposure will spoil the durability of the wheel. If such piercing is unavoidable, turn the drive switch on independently to rotate the wheel and start preheating, lifting the main unit up a little to prevent the heat affecting the wheel.

After cutting like this, the motor may not stop sometimes even after cutting is finished. This is not a fault but is caused by the valve not having been opened fully. The motor will stop, when the drive switch is tightened.

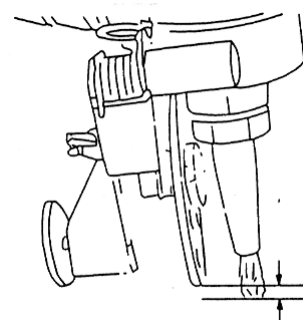

5.4 Procedures for starting cutting operation and extinguishing the flame

1. Align the tip with the cutting start point, ignite, and then adjust the flame.
2. Sufficiently preheat the cutting start point.
3. After heating, open the oxygen valve by turning it more than 1/8 turn, and the motor switch will be turned on, starting automatic cutting. When the valve opening angle is too small at that time, cutting operation will not be interlocked with the motor switch. When cutting an approx. 6 mm thick plate at a high oxygen pressure, the valve opening must be adjusted; therefore the motor switch may not be turned on. (Refer to the Cutting Data for pressure setting.)
4. Carefully check the cutting condition, and control the cutting speed with the speed adjuster. For the cutting speed, refer to the Cutting Data.
5. Extinguish the flame after cutting as follows:
 - 1) Turn off the motor switch (or turning direction switch).
 - 2) Close the cutting oxygen valve.
 - 3) Close the preheating oxygen valve.
 - 4) Close the fuel gas valve.
6. The guide roller is designed for stable and even cutting operation. But for preventing unstable tip movement such as might be caused by hose drag or the cutting travel, use of both hands, with the left hand supporting the cutting oxygen valve or the motor unit, when switching off the cutting oxygen.

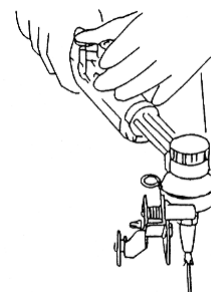

5.4.1. Thin plate cutting

When you cut a thin plate, 6mm thick for instance, adjust for a slightly weak flame, after selecting the tip size and the pressure suitable for the job according to the cutting data. Tilt the tip top forward slightly, then start the cutting operation.

Cutting with a too high cutting oxygen pressure or with too much preheating will cause incomplete separation of the material, or cause slag to stick on the lower edge of the cut.

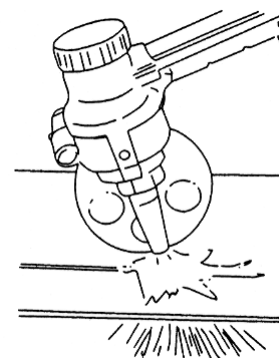

speed.

5.4.2. Bevel cutting

For bevel cutting, use a tip one grade above that for the specified thickness for straight cuts in the same thickness of plate in the cutting data, with a somewhat strong preheat flame and set the speed 20-30% lower.

The 0-22° bevel cutting is possible with the standard wheel, and the beveling wheel range is 22-45° . Insufficient preheating causes a cut surface in bevel cutting. Reselect the tip, readjusting the preheat and

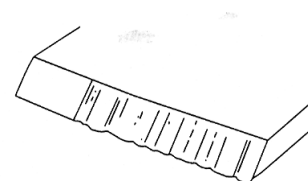

5.5 Safety measures against backfire and flashback

5.5.1 Prevention of backfire

Backfires may cause serious accidents or fires. Be careful to prevent such disaster. When a backfire occurs, find the cause and inspect and maintain the machine correctly before using the machine again.

The following are causes of backfire:

- 1) Improper gas pressure adjustment.
- 2) Overheated tip.
- 3) Slag clogged in tip.
- 4) Damage to the tapered section of the tip or torch will cause backfire.

5.5.2 Prevention of flashback

Flashback could cause fire and break the machine. Should there be a hissing sound in the torch, quickly take the following action:

- 1) Close the preheating oxygen valve.
- 2) Close the fuel gas valve.
- 3) Close the cutting oxygen valve.

Should flashback occur, find the cause and take appropriate action before using the machine again.

6 Maintenance and inspection

Refer to the following for inspection and maintenance of the machine and use the machine under the best operating conditions at all times.

6.1. Wheel Maintenance

As wheels are made of stainless steel (SUS-27), they are of rust-proof and have high heat and slag resistance. Even if slag sticks to the wheel, you can easily take it off with a wire brush or the like. Carry out periodic inspection and maintenance to prevent knocking or slag-sticking which may cause faulty power transmission to the wheel.

When the wheel knurls, become worn, replace the wheel. A worn wheel may cause slip and prevent operation.

6.2. Tip Maintenance

The tip used for the Handy Auto is designed for high durability combined with high safety. To maintain cutting quality, follow the correct instructions on maintenance and handling.

- (1) In piercing, lift the machine body up a little to prevent damage caused by the flame being deflected upwards.
- (2) Clean the orifice of the tip very carefully with a tip cleaner of the correct size.
- (3) Be careful not to damage the tapered seating section.

Replace the tip when the following occur.

- a. Even after cleaning, the cutting oxygen jet does not extend straight.
- b. The cutting oxygen jet flares at its end.
- c. During the cutting operation, clicking sounds are heard within the tip.
- d. Gas leaks from the fixing nut and burns.
- e. Pre-head flames are extremely uneven.

6.3.Lubrication

For greater safety, the Handy Auto has been designed so that lubrication is not necessary.

7 Trouble shooting

1) Motor does not run.

Possible Cause	Procedure	Remedy
1) No electrical power.	Check power circuit.	
2) Faulty fuse.	Check fuse.	Replace.
3) Faulty drive switch.	Check that clicking sound is heard by turning that the drive switch to the full extend. (This sound indicates the switch is not faulty.)	Repair.
4) Broken power cord.		Repair or replace.

2) Motor does not run. (Power is on.)

Possible Cause	Procedure	Remedy
Foreign matter on the beveling gears.	Check by removing the fixing knob and the head cover.	Clean.

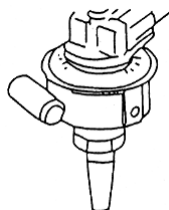

3) Motor runs but rotation is not transferred to the universal joint.

Possible Cause	Procedure	Remedy
Screw holding the speed reducer shaft to the universal joint is loose.		Tighten the screw.

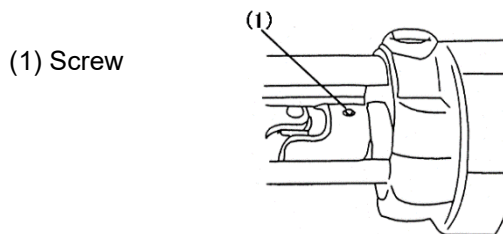

4) Beveling gear (Large) rotates but rotation is not transferred to the wheel or slipping and knocking occurs.

Possible Cause	Procedure	Remedy
1)Slag between the drive wheel and the beveling gear.		Clean

5) Wheel rotates but speed cannot be adjusted.

Possible Cause	Remedy
Faulty speed adjuster or transistor.	Repair or replace.

8 Wiring diagram

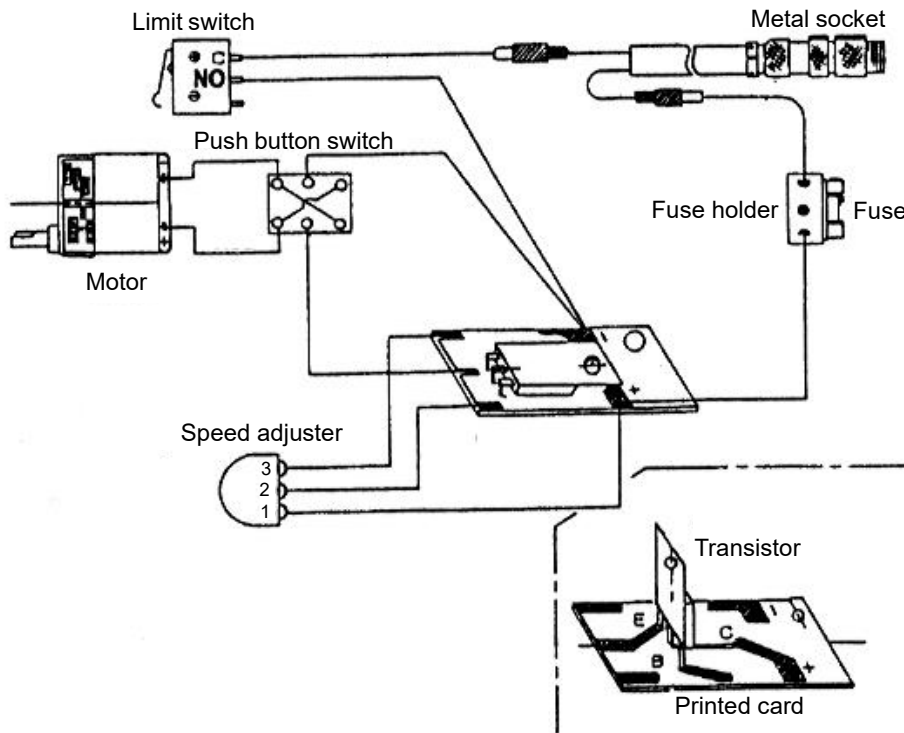

9 Electrical diagram

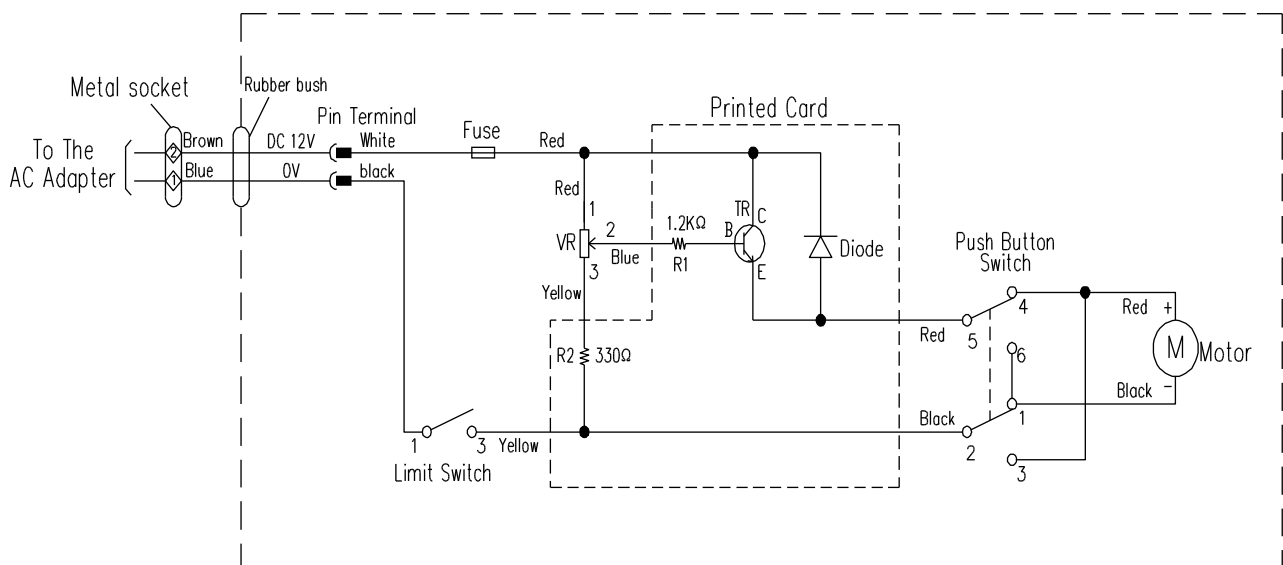

10 Assembly drawing of HANDY AUTO

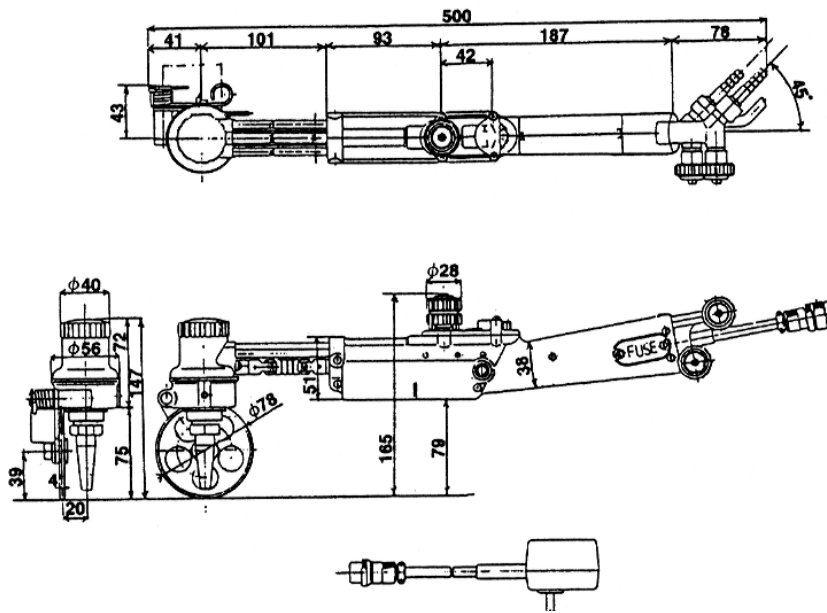

11 Parts list

11.1 Main units

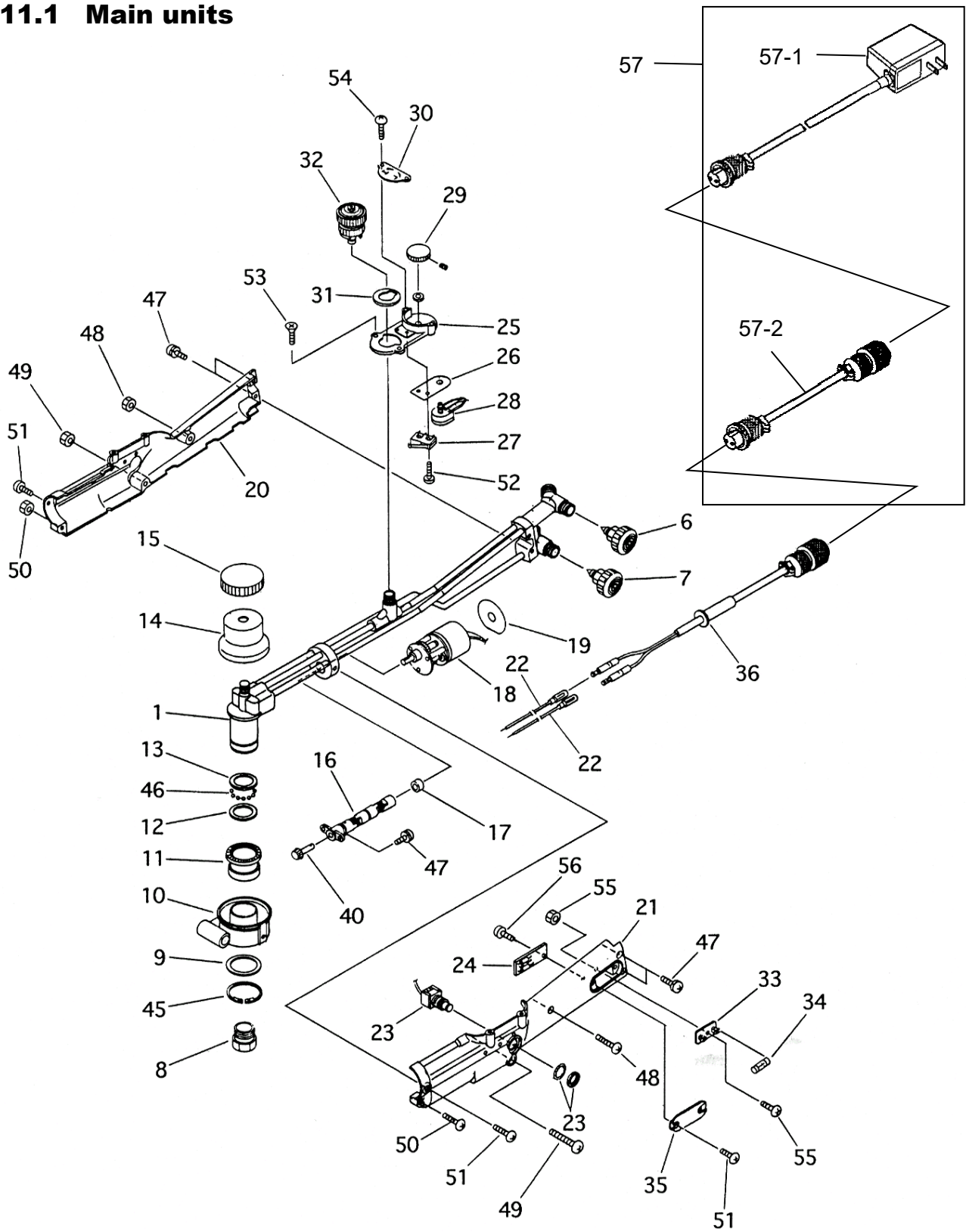

Main units

Item No.	Part name	Q'ty	Stock No.	Remarks
1	Torch	1	60030002	
6	Valve for preheat oxygen	1	60015255	Green
7	Valve for gas	1	60015256	Red
8	Tip fixing nut	1	60015032	
9	Torch head collar	1	60030003	
10	Gear cover	1	60030004	
11	Bevel gear	1	60030007	With DU bush
12	Thrust collar (Lower side)	1	60030008	
13	Thrust collar (Upper side)	1	60030009	
14	Torch head cover	1	60030005	
15	Position setting knob	1	60030006	
16	Universal joint	1	60030010	
17	Reduction gear collar	1	60030011	
18	Motor with speed reduction gear	1	61005294	
19	Motor insulating plate	1	60030038	
20	Main unit cover (right)	1	60030019	
21	Main unit cover (left)	1	60030020	
22	Mid way terminal	1	60030028	
23	Press button switch	1	60030022	
24	Printed circuit card	1	60030064	
25	Limit switch cover	1	20536556	
26	Limit switch insulating cover	1	60030017	
27	Limit switch	1	60030023	
28	Speed adjuster	1	20535930	
29	Speed adjuster knob	1	20537108	With screw
30	Speed adjuster cover	1	60030016	
31	Limit switch top	1	60030012	
32	Jet oxygen valve with knob	1	60030013	
33	Fuse holder	1	60030026	
34	Fuse	1	60030027	
35	Fuse cover	1	60030018	
36	Metal socket with cord	1	61004650	
40	Bevel gear (S)	1	60030062	
45	Stop ring	1	6B530280	ISTW-28
46	Steel ball	1	60030181	32Pcs/1Set
47	Screw	1	6C530410	SR-4x10,With WS
48	Screw	1	6C610425	SR-4x25,With NH
49	Screw	1	6C610435	SR-4x35,With NH
50	Screw	1	6C610418	SR-4x18,With NH
51	Screw	4	6C520408	SR-4x8
52	Screw	2	6C520210	SR-2x10
53	Screw	2	6C500408	SF-4x8
54	Screw	2	6C520418	SR-4x18
55	Screw	1	6C520306	SR-3x6
56	Screw	1	6C520406	SR-4x6
57	HA AC Adapter	1	20543811	※2
57-1	HA AC Adapter Cable	1	20543802	★
57-2	HA AC adapter extension cable	1	20543570	※1 ★

※1 Please do not connect 20543570 together to extend the cable length.

※2 Adapters contain electronic components inside. Dropping or hitting them can cause the internal electronic parts to break. Please handle with care.

11.2 Option units

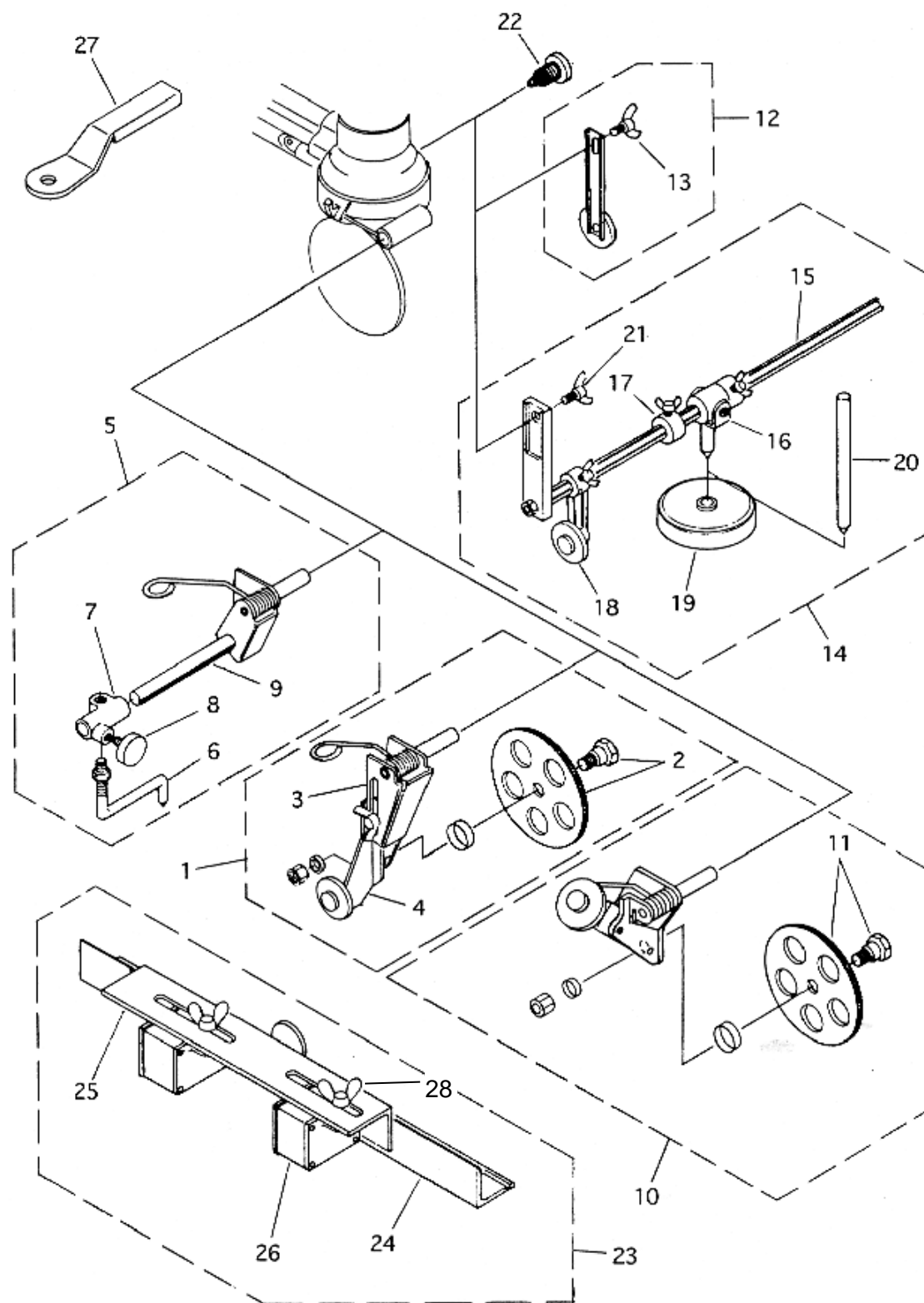

Option units

Item No.	Part name	Q'ty	Stock No.	Remarks
1	Standard wheel assembly	1	60030100	With shaft and nut
2	Drive wheel (3inch diameter)	1	60030107	
3	Standard wheel bracket	1	60030108	
4	Guide roller	1	60030109	
5	Small circle cutting attachment assembly	1	61001597	
6	Centering needle	1	61001556	
7	Centering needle holder	1	60030113	
8	Radius setting knob	1	60030114	
9	Bracket bar	1	61001559	
10	Beveling wheel assembly	1	60030102	
11	Beveling wheel	1	60030110	With shaft and nut
12	Auxiliary wheel assembly	1	60030101	
13	Wing bolt	1	60030126	
14	Large circle cutting attachment assembly	1	60030106	
15	Bar (19.7inch diameter)	1	60030120	
16	Free holder	1	60030121	With wing bolt
17	Stop collar	1	60030122	
18	Support roller	1	60038763	
19	Magnet	1	60030124	
20	Magnet center	1	60030125	
21	Wing bolt	1	60030127	
22	Clutch knob	1	60030115	
23	Straight rail assembly	1	60030104	
24	Rail	1	60030117	
25	Rail bracket	1	60030118	
26	Magnet	2	61001160	BS-5×10
27	Guide lever	1	60030105	
28	Wing bolt	2	6C120510	